

The FUELLESS HEATER

Copyright 2005 Creative Science ©
By The Unknown Author

The Fuelless Heater is a Trade Name of Creative Science

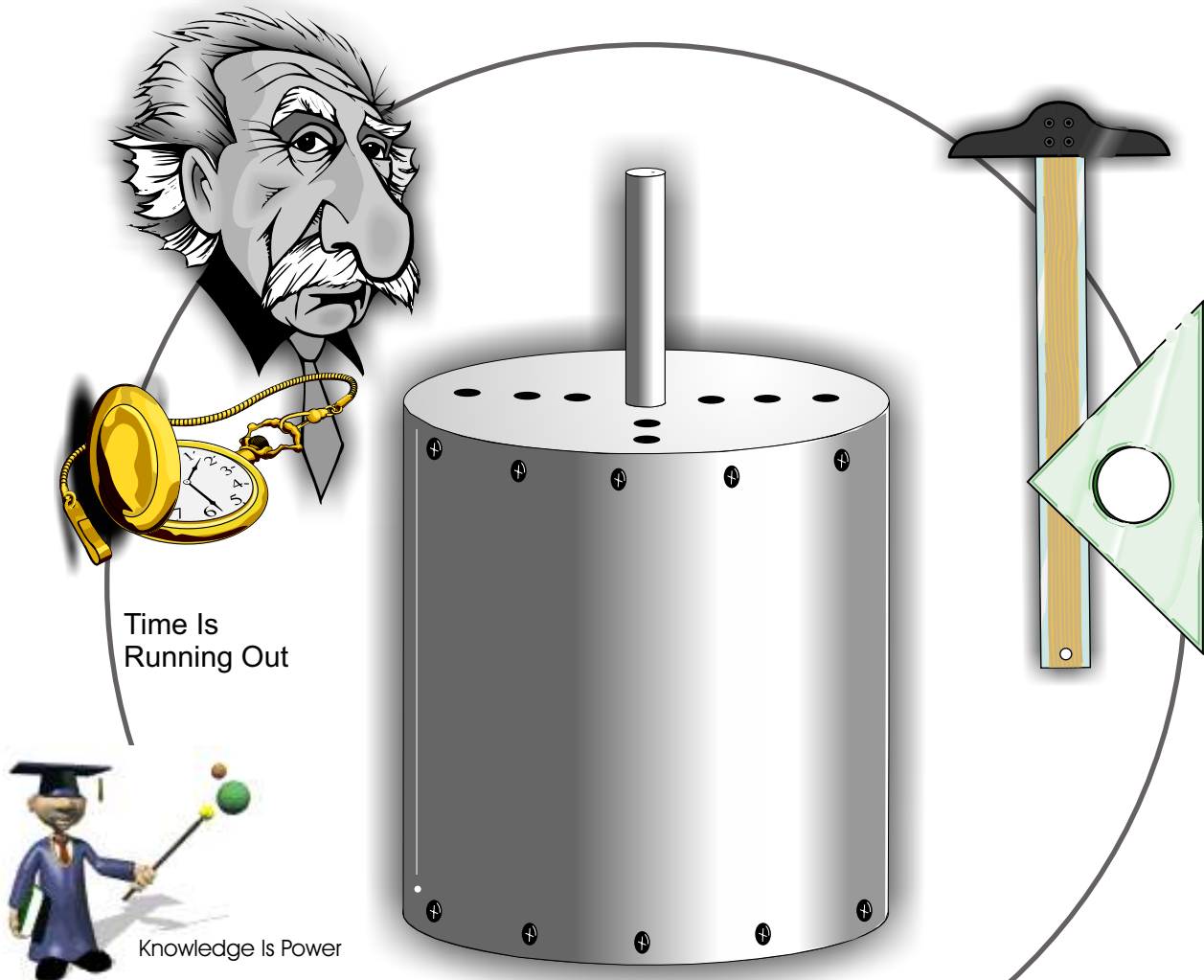

“ **Rick discovered this information** about 2 yrs ago while cleaning his office. It was sent in by an unknown customer about 4 to 5 yrs ago. The claim was so fantastic that it was hard to believe! It was then carefully constructed and tested. After testing the device he made some improvements on it and thus sprang forth a **new free energy heating device that was about 95 to 100% efficient** (our opinion). Every home can use this new heating device right now! It is the safest home heating source you will ever find in the entire world. And can save thousands of dollars in heating bills. **This device is considered to be a free energy device** or you could say a free energy collector caused by a moving capacitor plate (or drum) that collects free energy from the sub atomic atoms in the oil or liquid. We could even say it is collecting radiant energy from the atoms as well as the atmosphere? The free energy that is collected in the moving bottom plate or bottom inner drum plate is **electrical** and acts much like a **shorted out moving AC or DC generator**, which could be causing the heating effect. The free energy that is being created by the moving drum or cap plate is being reused by the heater, causing the efficiency to sky rocket! Most free energy devices must have some kind of input power to start the chain reaction of free energy. There is more here than meets the eye! We have done more on this device since then to improve it, much more than what we are allowed to show in these plans? These plans show you the basics on how to build this free energy device and can be used to heat your home. You will not waste your time, it is truly an awesome device and I know you will enjoy it as much as we have “

Thank you
David Waggoner

www.Fuellesspower.com
www.Fuelless.com



The Fuelless Heater is a simple device to construct and is proven to work! Some critics claim that the heater defies basic laws of physics but it does not. It can be considered as a controlled safe nuclear reaction! And can reach an efficiency of 100% and more if one takes the time to study and research it beyond what is in these plans. The basic free energy heater in these plans can be used to heat a home and has done so with great success!

It is clear that the internal energy of the atom is being tapped here. It is not just a matter of friction but far more than this. When you trap an atom and apply pressure in the form of friction - temp., interesting things start to happen. Pauli's exclusion principle tells us that two electrons are not allowed to do the same thing, to follow the same course and especially to get near one another. Each time that an electron is forced nearer another electron, the other one must move away, refusing to share an orbit. So each time that an electron is forced to change orbits or levels, One QUANTA or One PHOTON of light - HEAT ENERGY is giving off! Each electron changing levels forces a series of other electrons into the same fate, Like a small chain reaction.

Every home furnace or space heater uses an electric fan motor to blow the heated air around the rooms or room. we are simply using this same motor to do another function, to turn the inside rotor drum (or capacitor plate) that will in turn cause the atomic chain reaction in the liquid that is being used within the inner part of the outer drum as stated above. Our Fuelless Engine can do the job or a solar panel can be used to run a high efficiency DC fan motor, which will start the atomic reaction. The space between the bottom plate or outer drum and the inner rotating plate or inner drum should be 1/4" no more or no less. The rotor shaft should be about 3" diameter for a large 25" heater drum and about 1" for smaller heaters. Using a large shaft will give the shaft more leverage and less resistance.

The Tesla Turbine Engine invented by Nikola Tesla in the 1900's can be very useful,, also in that it can run this heater at higher levels of efficiency. We sell the patent for \$11.95 order #393 see our website at: www.fuellesspower.com or www.fuelless.com

The amount of oil needed to add to the heater will depend on what type of inner actuator you use. We have researched and designed many different types. Some are classified! On one of our bean can heaters we filled the can with about 95% oil and sealed it tight with high temp 2 part epoxy. Since the heater is creating free electrical type energy you do not want to short it out. The inner rotor can must not come in contact with the steel or aluminum outer drum. On our bean heater we used a 2" thick wood, cut to the same inner diameter as the top of the can, as the rotor shaft guide and electrical insulator to test the heater. It worked great! **We reached 167 degrees in just 2 minutes.** There are many ways to build this heater. It may be faster and cheaper to search the internet for cooking pots. There are many sizes that will work great with each other.

For fireplace and space heater use. The Resistance of the inner drum on the motor is very small. Over the years scientist have tried to invent a way to heat a home using solar electric panels, but failed, the energy it takes to heat a home is too much, it would cost a Solar Panel Customer over \$15,000 in solar panels to even come close. and is still not enough to do the job. This heater is the answer to all the worlds heating problems.

Just think about it,, a heater furnace that uses atomic friction instead of fuel to heat an average size home for only \$10 - \$15 per month, FREE if the home owner uses one solar panel to run fan blower motor. or a Free Energy electric motor! I heard of a man who built this Free Energy Heater out of a 10 year old washing machine, can you believe that? That's how simple this is to make. He had an old home and it was costing him over \$230 to heat. His wife probably thought he was a nut! but once he built and tested it he then hooked it up to a thermostat and by passed it into his old Furnace and heated his home for just 50 cents per day. (True Story!) How can I describe this thing? Is it like a moving 2 plate generator capacitor with a 1/4 gap?



Another option is to run your blower fan motor with the power from your power company just as you are doing now and reduce your heating bill. The gas company may ask you what is going on? There is another reason why I love this heater, every year it seems someone's house has blown up because of a natural gas leak problem. Or a family has died because of gas poisoning. How many more have to die? It's crazy! This heater is the answer our country has been looking for.

I have personally seen 2 houses in my life time blown to pieces. It's stupid to use gas now that you have these plans. If you don't know what you are doing then please get a heating and cooling company to help you or a machine shop to construct each part for you and then you can put it together as you would a kit. If you build a multi disk Tesla Turbine Engine to turn the rotor shaft you can get a machine shop or laser cutting company in your area or on the internet to cut the round sheet metal disks for you as well as the 1/4" space washers. You do not need to tell them what it is for. See our Tesla Turbine Patent.

The bigger the unit is made the more BTU's and the faster the unit will heat. If you build a larger heater make sure you use the largest round rod shaft that you can find (about 3") it does not need to be zinc but it would help, you could always spray it with zinc paint. The idea is to get as much leverage as you can to lower the shaft resistance. But not to big as to restrict the oil or other liquid from moving on the plate~ surfaces. You can then attach a pulley wheel to the shaft. You can find these pulleys at Grainger.com. Grainger will only sell to business's so start your own research business and name it what ever you like.

PLEASE NOTE: You BUILD at your OWN RISK! we are not responsible for anything in these plans. Always put safety first! This information is for research purposes ONLY!

Our small bean can heater experiments etc.. 167degrees in just 2 to 3 minutes



2500 to 3000 rpms



We had to use aluminum duct tape to keep the hot oil in. Use 2 part epoxy for perm.



There are several ways to build a simple working model. The rotor and the stationary parts have the same geometry. This may be a drum shape cylinder or other.

Start if you like with a small model using 2 metal cans. The one that fits inside the other should have about a 1/8" clearance all around it's sides. and a 1/4" space between the inside of both bottoms. To test, use a hand drill or best to use a small work bench drill press, or better yet if have a high efficiency solar powered dc motor or our fuelless engine motor already built you can go ahead and use these.

This will start the atomic reaction within the thin oil that is in the bottom of the can. we built our soup can heater and it produced about 92 degrees in just 12 minutes at 1700 rpms, 3000 rpms would cut the time in half. 6000 rpms are even better. **NOTICE:** Anything over 1700 rpms will need a very well balanced rotor drum which any machine shop can make for you. A solid steel rotor cylinder turned on a metal lathe should work just fine. We have had customers who have taken the time to research there soup can heaters and some have reached higher temperatures than this. The inner rotor drum or other type of rotor actuator should be made of steel, sheet metal is best. **Do not make the inner rotor drum or actuator out of aluminum,** the aluminum will draw the heat to itself and to the shaft. Most tin cans have ridges on the sides of them, this is what we used in our first model, but it is not recommended. This small Soup can model should be proof to you that there is an atomic free energy reaction taking place inside the oil or water. Be sure to use high temp automotive silicon to attach parts. Use wood for the top. Use a Craftsman Wheel and Circle Cutter, Sears part number 9 25293 See Sears.com key word search " Circle cutter "

The bottom rotor pivot mount can be wood, drill a hole all the way through, double the size of the shaft rod or bolt. Then fill hole with J-B Industro WELD 2 part epoxy, let it dry for 1 day and then drill your pivot hole for your shaft bolt to ride on.



Zinc Rod or zinc plated bolt
This is the rotor shaft!

Soup Can Heater.

Or use a Large bean can

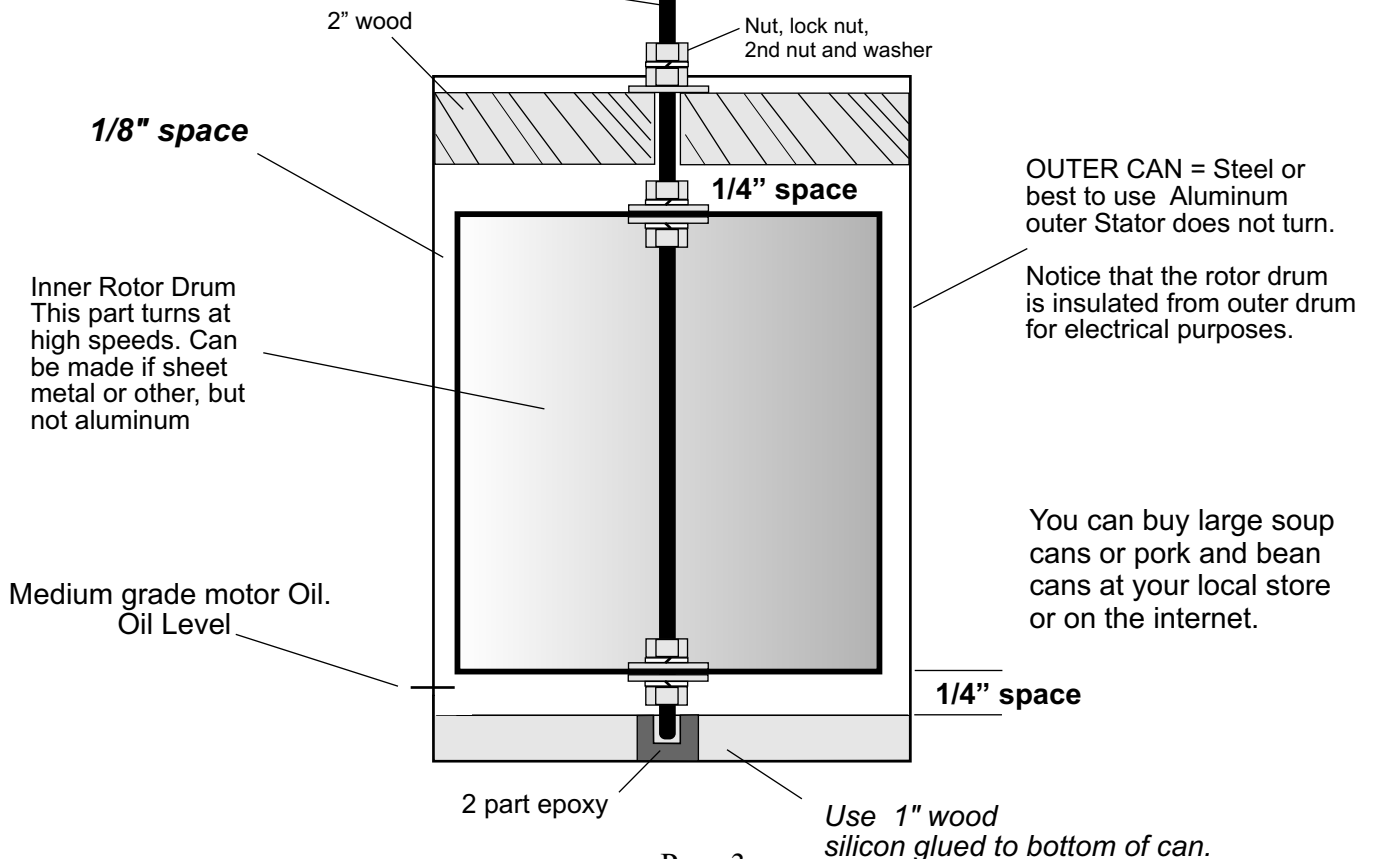

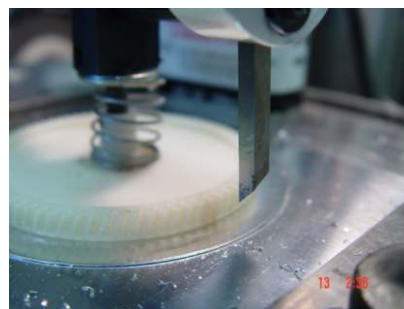





You can cut the 2" wood for the top and the 1" or 2" wood disk for the bottom by using the Sears Circle Cutter attachment in a drill press. Use C-clamps to hold the wood into place and begin cutting at 400 rpms or less. Wear protective eye wear. Take it slow. You can control each layer you cut by using the drill press adjustment depth nut on the left side of your drill press. Cut 1/16" or less cuts at a time, move your nut about a 1/16 of an inch at each Pass of the cutter. You will have to cut the wood down to one inch. To do this you will need to widen the cut every 1/4 inch or so so your cutting blade will not lock up. You can cut all the way through doing it this way or you can flip the wood over and cut the other side until you cut a perfect wood disk. It is best to cut the wood disks a little to big, best to have to much than to little.) you can use a Craftsmen disk belt sander to sand down the edges until you get a tight fit into the can. The wood disks should fit tightly. Once you have your first prototype built, first try it **without** oil by just using the air, the results will be -0- . You will get nothing. Now try pouring in a small amount of thick oil on the bottom and turning it again. The can will now heat up. The wood disks you are using will not burn up and seems to be very safe to use. Again this device is considered to be a free energy device, It reuses the free energy to help create more heat. There is some type of atomic reaction taking place here which I believe is could be cold fusion and or Radiant energy. it is a safe atomic reaction as far as our test have shown. Hundreds of people all over the world are already using this heater with no problems. Just keep in mind there are better ways to build this heater. Again you will want to turn the rotor with our Fuelless Engine or the Tesla Turbine.

I believe that the liquid molecules are set into greater motion due to the rolling friction between the stationary and the rotating drum or other. Aluminum is the best material to use for the outer drum. A mechanical resonance can also occur in the liquid at the right thermal vibration. This will increase the heating action. Other constructions, sizes and shapes can produce CAVITATION and SHOCK WAVES! The design and geometry has a lot to do with it's overall performance.

The world is seeing a new type of energy production here using the same old type of atoms that have been here on the earth since God created the earth. These atomic cold fusion heaters can be very simple in design and can be operated at very low speeds as well as high speeds.

Send us pictures of your finished heater and any new ideas we can pass along to others. I hope you enjoy working with this new and awesome invention as much as we did. There is yet so much more to discover and so little time to do it in. Mankind has only scratched the surface of electrical and magnetic technology! There is so much more yet to see, so much more to discover.

Thank you
David Waggoner
Creative Science & Research
PO BOX 557
New Albany, IN. 47151

www.fuellesspower.com

sales@fuellesspower.com

www.fuellesspower.com

Circle Cutter



Tesla Turbine motor



Tesla Turbine motor



Tesla Turbine can be ran by steam or air



Paint Can Heater

Model #2

DESCRIPTION: An inner drum rotates inside an outer drum, Inside oil is rotating with the inner drum and rising up into the walls of the inner structure of the 1/8" spacing which is evenly spaced. Outer drum does not move. In this model the inner drum shaft does not go all the way through as shown. The atoms are then moved in a way as discussed earlier. Again, I also believe that an electrical and magnetical flux from the atoms are taking place and causing the inner drum to work as a shorted out high amp generator, thus causing HEAT! The liquid can be any type of liquid such as; Coke, (or soft drinks), coffee, Oils, Transmission fluid, Brake fluid, Water etc... I have found it best to use medium grade oil, but I am still researching this. see what you can come up with. The Fuelless Heater is a True free energy machine! It is not a perpetual motion machine but can be made that way. Solar cells are also free energy devices but are not perpetual free energy. The oil is not used up, I'm sure it would take many years for it to be consumed at all. These units can also be made to heat your hot water heater or used as a steam generator to generate electricity for your home using a steam Tesla turbine connected to our SP500 generator or windmill generator. Below is a drawing of our paint can heater. On the outside we use aluminum roof flashing and on the inside we use a metal paint can. The tops of the outer container can also be wood and or high temp plastic. You could also make the top and bottom plates out of 2 part epoxy using a mold. For testing purposes we are using 1/4" steel (laser cut). The shaft bolt then must be plastic nylon or if you use steel or zinc plated bolts you must paint them. Notice the bottom plate must be painted with 4 coat's of high temp engine spray paint. Or you can use a flat 1/2" tall High temp plastic O-ring to be placed around the outside of the 1/4" steel disk.

Plastic Nylon

1/2" Top Shaft Bolt
or can be any size.
(Turns inner can = rotor)

Oil Fill Spout

Optional

Inner drum

Can be made of
steel, metal or
stainless steel. this
model uses an empty
paint can.

1/2" Flange Bearing Optional
make holes a little bigger than
the 2 bolts, so you can move
flange bearing and line it up
center, then tighten bolts.

1/4" inch Space

Front View

1/8" space

Aluminum outer drum

Aluminum roofing flashing
from a hardware store.

small machine bolt, (use high temp STEEL Bolt.)
Bolt in center of bottom inner drum and then round
off the tip of bolt with a sander or file.

Inner drum shaft bolt 1/2" hex bolt with head cut off, nut,
2- washers & one lock nut, centered in top of drum, which
we are using an empty 1 gal paint can. this works great
because the lid comes on and off, for easy assembly.
1/2" bolt hole will need to be 1/16" bigger once you have
attached and lined up your flange bearing, or just run
your unit for a while and the wear and tear will make the
hole bigger. apply grease to this area. Experiment with
different levels of oil. It is also optional to attach a
copper or steel oil fill and drain spout with threaded air
tight lid. Use high temp 2 part epoxy to glue it in place
before inserting and after you insert it. Must be air tight.

Bottom plate

Plates are cut by a laser cutter, we use 1/4" steel for testing only,
Plates must be painted with high temp automotive engine paint.
But best to use 1" to 2" thick - 2 part high temp epoxy or high temp
plastic or wood to prevent electrical short. Steel can be used but
seems to be less efficient. The bottom and top plate must be the same
diameter. each plate will have holes drilled in sides and tapped out.
If thicker material is used you must account for this as use taller
aluminum flashing.

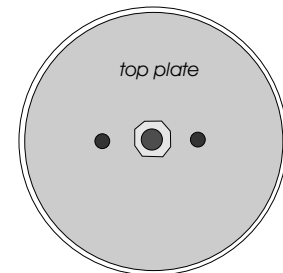

top view
Drill 2 holes for flange
bearing to fit.

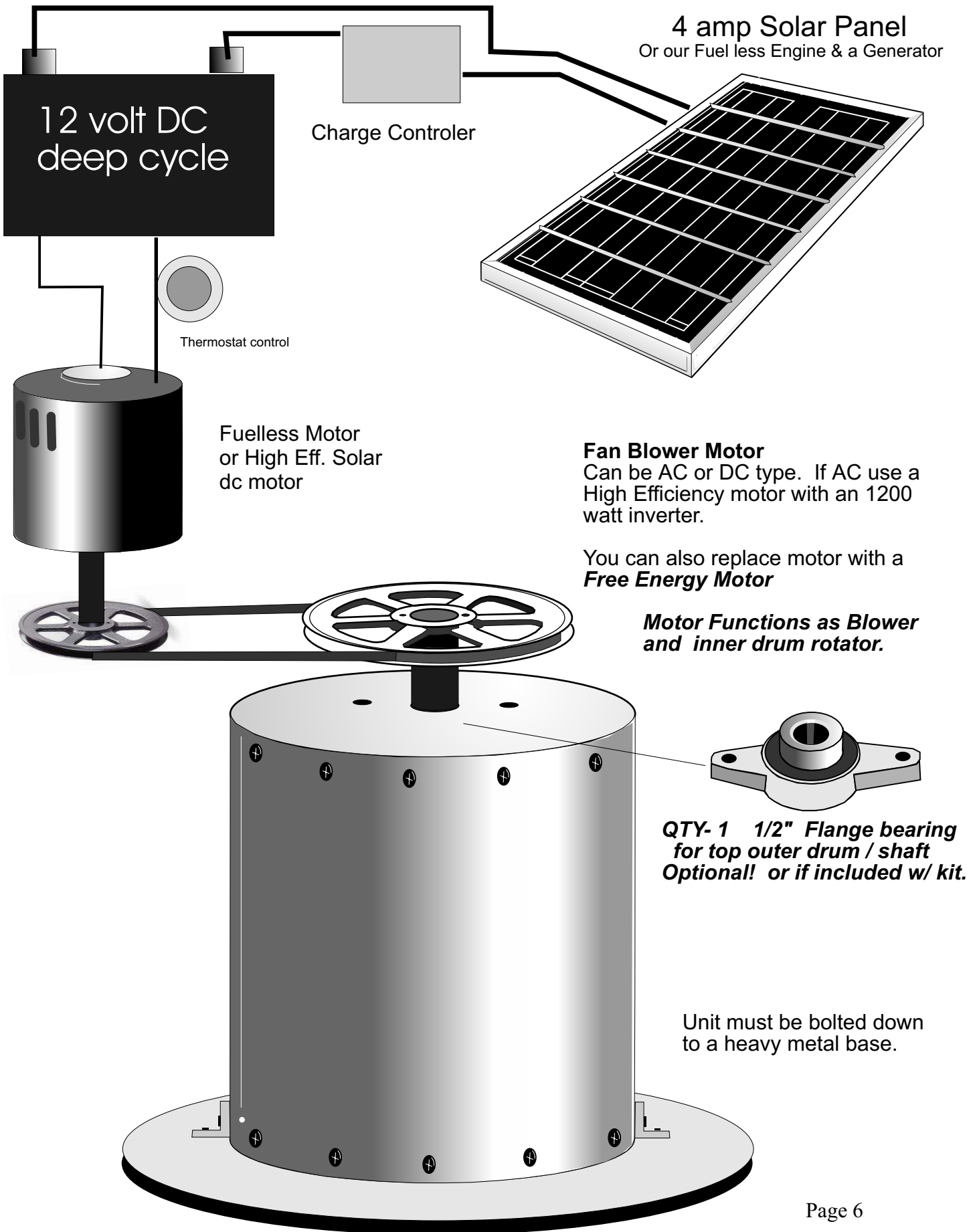

4 amp Solar Panel
Or our Fuel less Engine & a Generator

Charge Controller

12 volt DC
deep cycle

Thermostat control

Fuelless Motor
or High Eff. Solar
dc motor

Fan Blower Motor

Can be AC or DC type. If AC use a High Efficiency motor with an 1200 watt inverter.

You can also replace motor with a **Free Energy Motor**

Motor Functions as Blower and inner drum rotator.

**QTY- 1 1/2" Flange bearing for top outer drum / shaft
Optional! or if included w/ kit.**

Unit must be bolted down to a heavy metal base.



Top Outer Drum Plate = Stator housing
 6 7/8" diameter - Steel or Aluminum
 1/4" Laser cut steel \$69 ea.
 3 - 7/64" diameter drill holes, machine bolt.
 6-32 x 3/8" tap. Paint the entire plate with
 high temp spray paint.

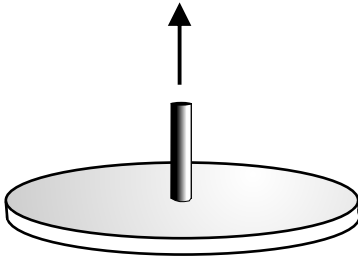

Inner Drum: Paint Can Lid. with 1/4" bolt x 4"
 w/ 2 washers, 1 lock washer, 2 nuts.

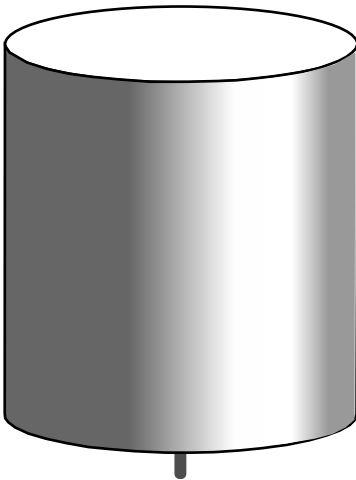

Inner Drum: Paint Can, 1 gal. 7 5/8" tall x
 6 5/8" diameter.
 You can buy an empty can at a hardware store
 or paint company / container co. or you can
 have a special steel drum machined by a
 machine shop in your area. - STEEL

You can build the parts yourself or have a
 machine shop do them for you. If you decide
 to have a machine shop do it. Take them a few
 parts at a time it is cheaper and they will not ask
 questions. Please keep this confidential.

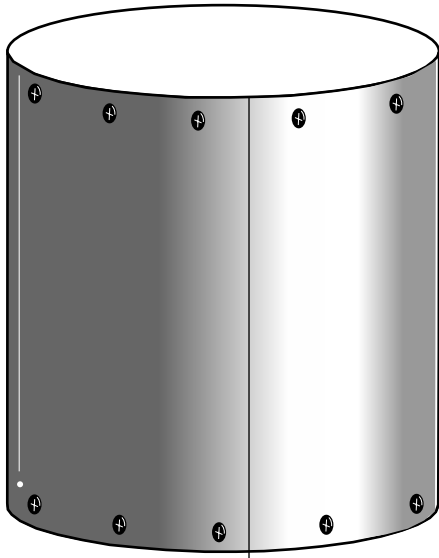

Outer Drum = Stator
 Made of Aluminum roofing flashing, you must
 glue together with seam with automotive fast
 weld or epoxy past. hardens like steel. use a 1
 5/8" x 10" steel pipe to Curve the sheet of
 aluminum. see video.
 holes must be drilled to attach the top and
 bottom steel plates.

Carefully study the Tesla Turbine engine



Outer Drum Bottom Plate; Center hole is not
 drilled all the way through. 3/16" x 1/8" deep.
 Steel or Aluminum. Paint the entire plate with
 high temp spray paint.

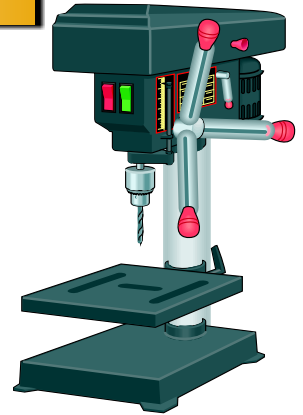

There are a few things you will need on your part to build this Free Energy Heater.

1. 2" grey Duck Tape
2. Screw driver and hammer

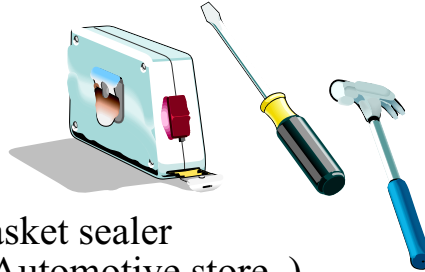

3. Copper Plus High temp. Gasket sealer
700 degrees silicon type. (Automotive store.)
This is used to help seal the seam of the outer aluminum drum and to seal the bottom of the heater plate, to keep the unit from leaking any oil or what ever liquid you use.

4. 1 5/8" x 12" metal Pipe.
This is used to round the Aluminum flashing so it will fit well around the laser cut 1/4" round metal, = top & Bottom of outer drum. You will first drill your holes top and bottom and then you will need to round off.

5. Hacksaw

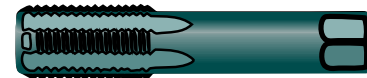
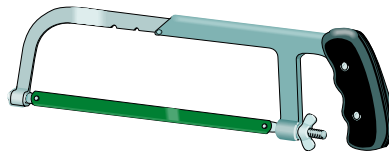

6. Fas - Weld Automotive Repair epoxy
This can be used to weld the seam together, it is rated for high temp. and is like steel when dry. Surface area must be sanded and cleaned with paint thinner and dried very well before applying. You can buy a thicker aluminum so a welding shop or machine shop can weld it for you. you will to find a fabricating shop or machine shop to round it for you. it can be done very cheaply. I think 1/4" aluminum is best to weld?
7. PC-7 Heavy Duty Multi- purpose Epoxy Past.
This is not highly recommended to use to weld your Aluminum seam, it is only rated for 200 degrees. But it will work and is a bit easier to work with. it is a 2 part mix epoxy that you can buy at any hardware store.

8. DRILL PRESS; This is best to use and is more accurate than a hand drill.

9. Tape set 6 - 32 Machine Screw thread, Drill bit size = 7/64"
If you did not buy the kit, then you will need to have your own top and bottom plates cut, You will then need to drill holes in the 1/4" sides and then tape them out. (Thread them)





There are many ways one could design this heater. Below is just another example. It would be less wear on the motor if you use a pulley and take the motor out away from the heat. The result will also be more high efficiency for the motor. The hotter the motor gets the more amperage it will use. The unit could be designed to blow the air downward and out the right side of the outer casing. the top would suck room air into it.

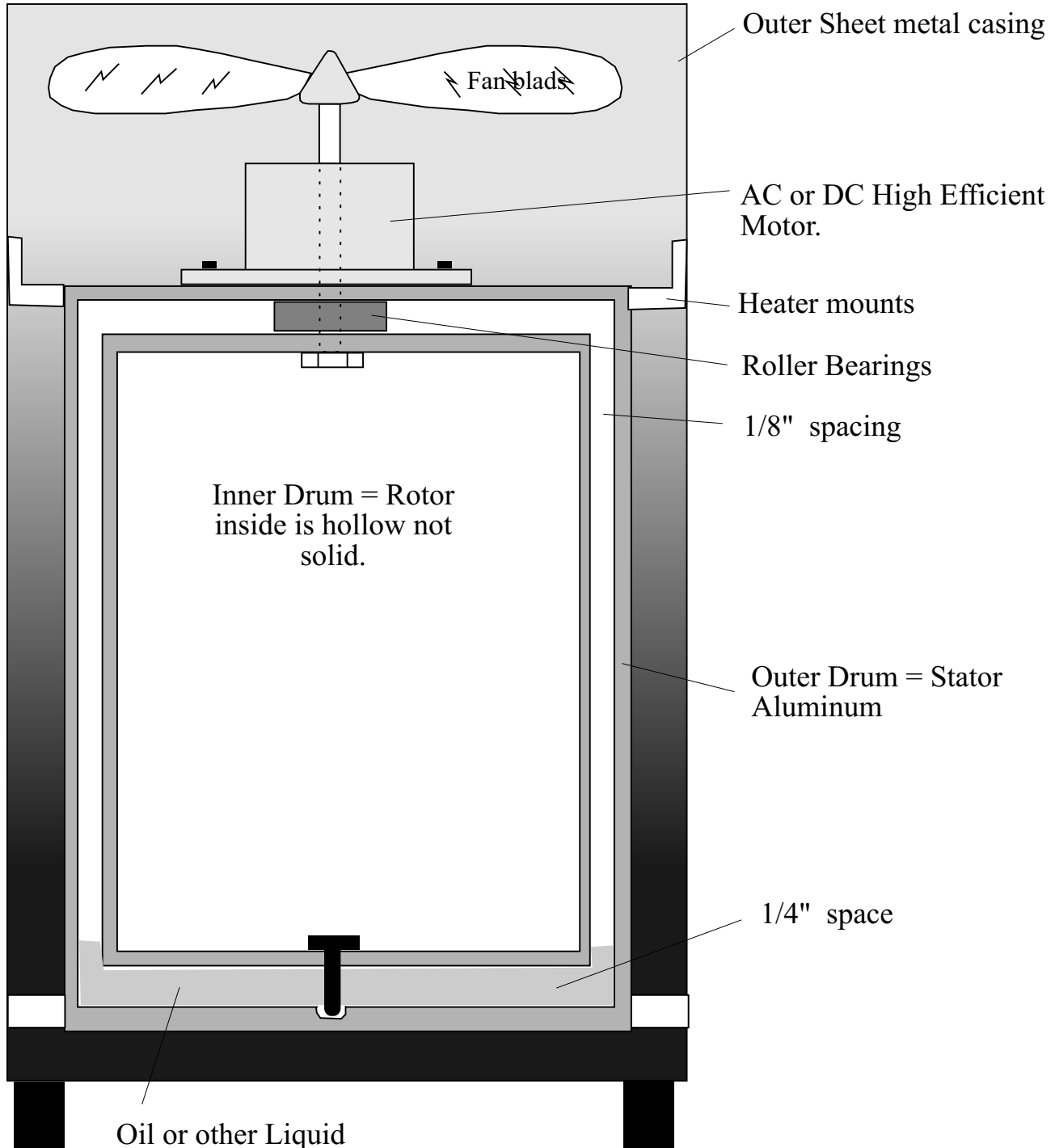



Outer Drum = Stator

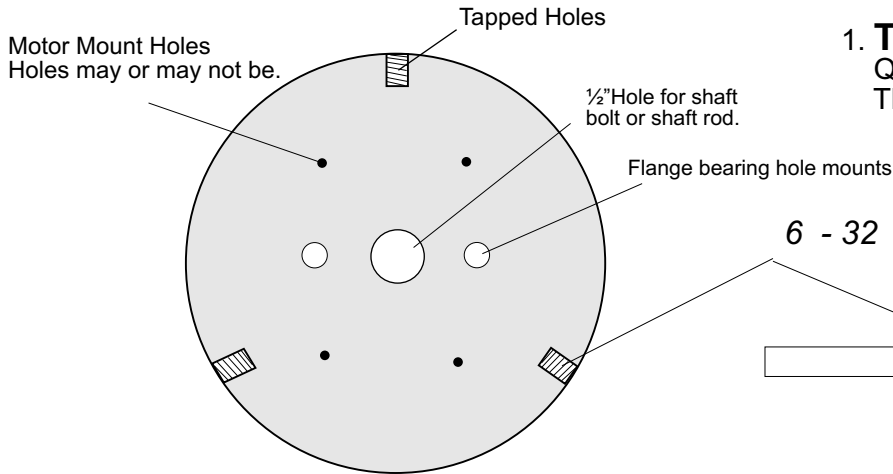

Top View

1. Top plate

Qty-1 6 7/8" Diameter X 1/4" Thick, TOP PLATE.

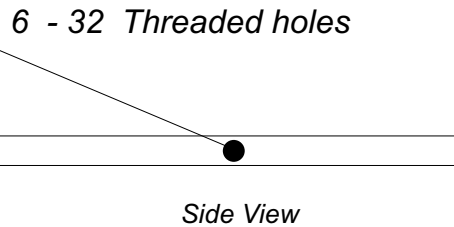

2. Machine Screws

Qty-12 - 6-32 X 3/8" .
to attach outer aluminum drum wall.

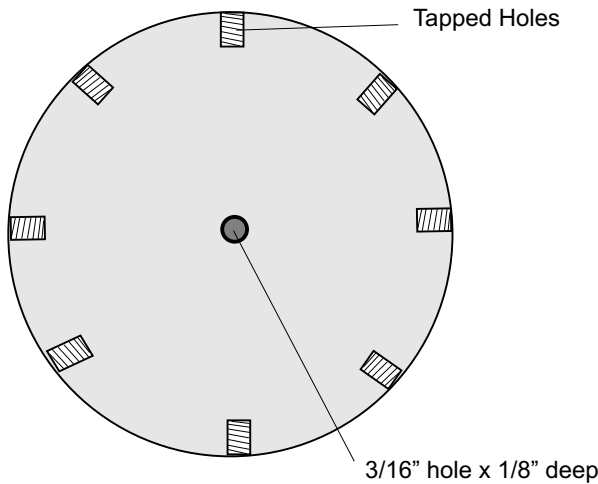

4. Bottom Plate

Qty - 1 6 7/8" x 1/4" steel - Bottom plate. total of 8 7/64" d. holes. tapped.

Side View, shows center drill hole 1/8"

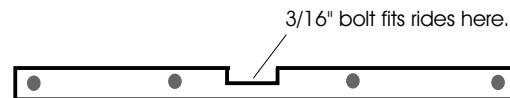

Flat aluminum Sheet

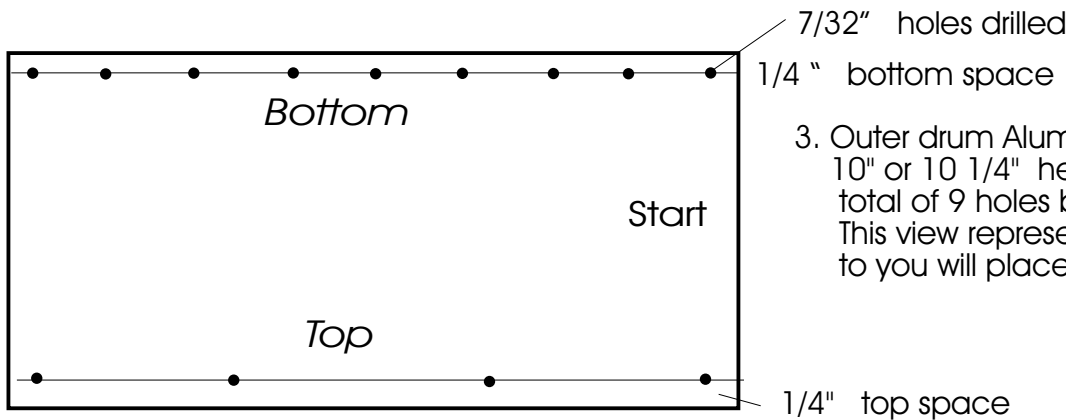

3. Outer drum Aluminum case.

10" or 10 1/4" height X 23 1/4" length.
total of 9 holes bottom, 4 holes top.
This view represents the inside of the drum, as to you will place your marks, see page 11.

You must mark your aluminum sheet on one end with your fine point marker and write starting point. then on your top plate mark one of the holes start or A. and draw a small start line there. Now on the flat sheet of aluminum draw a straight line across the top, 1/4". this line is where you will follow when you roll your plate to mark it. all plate holes should be marked on the top to indicate where the holes are. this is to help you when you go to rolling and marking the holes. Now, start rolling the plat VERY slowly to the left and when your hole marks are flat on the sheet, MARK IT! continue rolling and marking until you run off the sheet. These markings are where you are going to drill your 3/16" diameter holes. You should have a total of 4 holes. Yes your top plate does have 3 holes, but the extra hole is for the over lap seam. Be careful when you roll the plat, do not allow it to slip. let the weight of the plate do all the work you just guide it along the line you made.

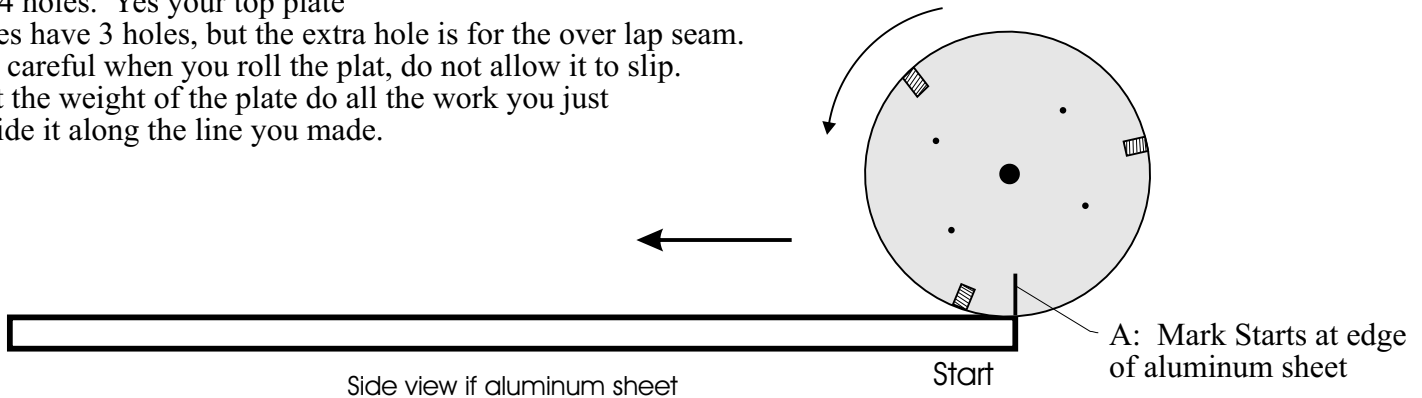

Now do the same thing to the bottom plat. Make sure that you place the bottom plat on the bottom of the aluminum sheet. Now once you have made all your markings, drill your 3/16" holes. keep in mind they must be very accurate or the tap holes will not line up with the sheet holes. Once you are finished drilling holes, take the sheet and tape one end to the 1 5/8" x 12" metal pipe, and roll it into shape. see video.

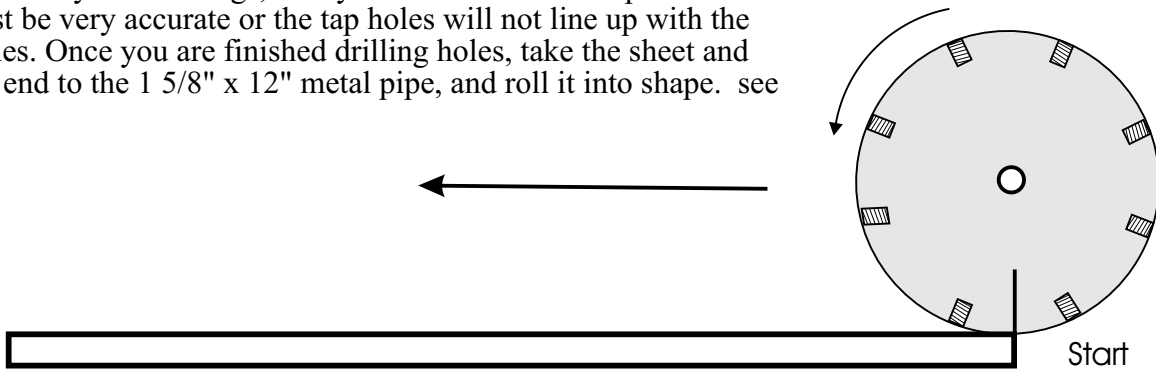

Round Off Aluminum Sheet

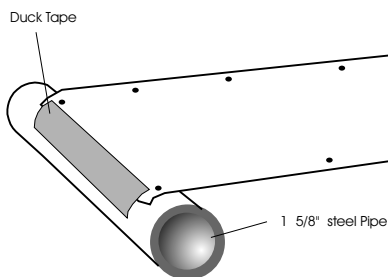

Now wrap the aluminum sheet around the pipe a few times until it take a curve shape. Once this is done you must check to see if the holes line up together with the top and bottom plates. This I will call the dry run. Using the small screws, attach the sheet to the bottom plat first, then the top. Now if all lines up well, Take the screws back out and start w/bottom, apply 700 degree copper plus epoxy. now start bolting bottom back together. when you get to the last hole, apply some to the inner seam. (Not all.) You will be applying the PC-7 epoxy to the outer seam, The inner seam gets the copper plus all the way up. now apply the last screw. now start on the top plate, no need to apply any epoxy here. (at least not for a long while. test unit first.) Now apply the PC-7 epoxy using a butter knife, apply evenly. now tape seam and let sit 24 - 36 hours.



The Fuelless Heater

Now at this point you should have a very nice tightly fit outer drum. take off the duck tape, now apply the copper plus epoxy to the inner part of your outer drum along the inside seam, doing this will give it extra strength in fewer leaks. (NOTE: Be careful not to cut your self when handling, aluminum is like a knife!) (See our Video)

Now apply a small bead of copper plus on the bottom inside all around the inside radius, then using your finger smooth it out. do not apply to much. Let this epoxy sit for 3 days, (I know you are very anxious to get it up and going but you will thank me later.)

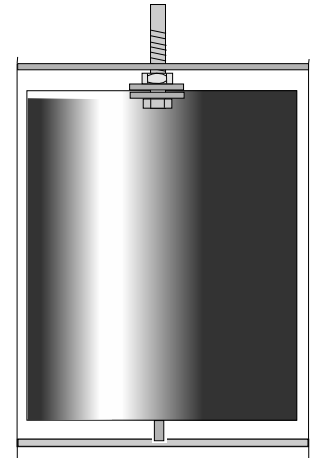

NOW THE PAINT CAN: Make a center mark on the lid and a center mark on the bottom of can. If you don't think you can do it, then find a local machine shop do drill the center holes for you. It must be centered or you will be off balance as it is running and that is not good on the motor.

Once you have your center holes take the lid and place your 1/4" x 4" long bolt into it. Actually the bolt can larger if you like. Use a lock washer and 2 large washers with nuts. now for the bottom of can. place a 8 -32 x 1" machine screw in the bottom. again use a lock washer and large washers with nuts. you can use an open bolt or a bolt with a head on it. Now the screw must be coming 5/8" out of the bottom. remember you need 1/4" space from bottom of paint can or edge, to the bottom of outer drum. I am accounting for the 1/8" pivot hole. using nuts and a washer on the top lid, apply as many as you need so that once the drum is in it will not move up and down to far. up and down movement should be about 1/16 of an inch play. Now add transmission fluid to bottom of outer can = stator. place paint can into outer drum and put the top plate on. 1/4" shaft bolt should go through the top plate center hole. Paint can should move very easily with your fingers. Now place your new heating unit under your drill press to test it at 1500 rpm to start.

apply a kitchen oven turkey thermometer to the outside. (Tape it) now watch the heat rise. Write down your room temp. if you did everything right the temp. should rise very quickly. The larger you make this heater the better.

Now that you see it works you can now design your motor mount etc....

A Fuellers Heater Model "C"

For educational purposes let's look at another design. This design uses the same simple paint can heater model as shown earlier but free energy electromagnets are added to the outside. This design was invented by Rick & Dave of Creative Science and Research but nothing has been done with it yet, nor has a prototype been built and tested yet.

As you may not know, by rotating a steel drum in a strong magnetic field, will produce heat within the steel or aluminum drum which is acting as a shorted out generator causing heat! As you can see below we designed it to use 4 high voltage DC pulsed electromagnets. (Back emf is collected using diodes and caps). The iron core is not like the iron used in transformers or other magnets. we want this metal to become a permanent magnet by the on and off pulses of the DC coil. So we recommend using a cold steel metal or other type metal for the cores. A metal unlike iron cores that are used in motors or transformers today. Electrical engineers who designed these type of electro magnets or transformers do not want the metal to become permanently magnetic. but in this case we want as much as we can get and you want it to last as long as you can get it to last to bring the efficiency way up. This should also save on energy and produce a higher efficiency in heat output. . The steel cores of the magnets can be laser or die cut to a special curve and each laminated piece can be about 1/8" to 1/4" thick. The DC input pulses would be much like the Ed Grey Electrical Patent, using capacitors to step up the 12 VDC solar panel voltage to a high DC voltage of about 600 DC volts x 1 amp, the back emf (Which is free energy from a collapsing magnetic field) is collecting and placed back into the 12 volt dc deep cycle battery. Again use a 5 amp 12 volt solar panel with 2 deep cycle 12 vdc storage batteries. and you will also need a voltage controller. Again to explain the inner action of the heater. Energy is collected between the 2 plate surfaces at the bottom of the heater. We believe electrons, as well as radiant energy is being collect there also and thrown back into the mass arena of fast cycling sub atomic atoms of the oil. This causes a ping pong effect. A small amount of energy is believed to be imputed and a large amount of energy is outputted and reused by the heater causing a massive heat chain reaction.

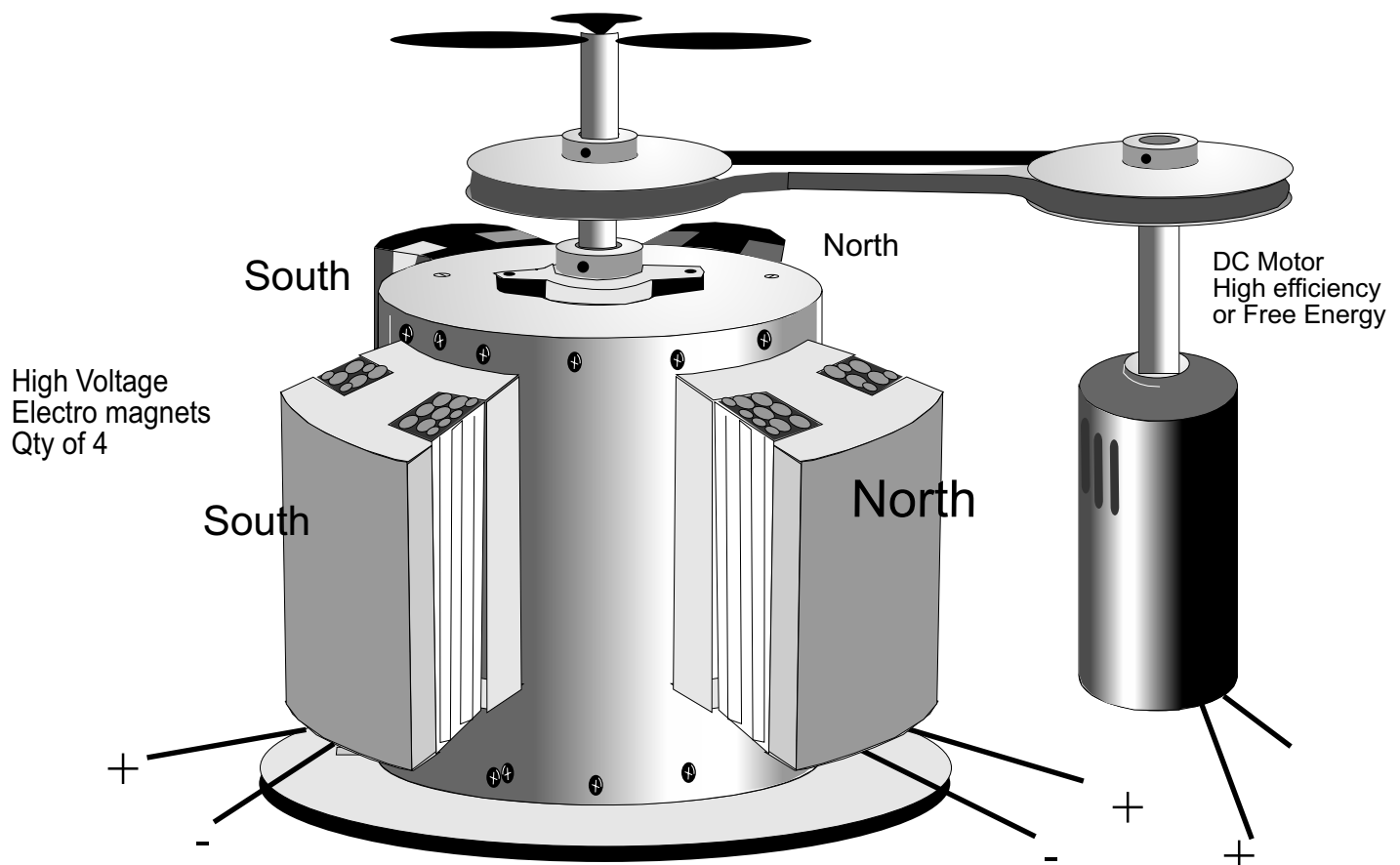

The coils can be wound with about 1,000 to 2,000 turns of #26 copper coated wire. Notice the top of the magnets in this drawing are cut off just for display purposes, the windings go all the way around the steel core. If you need to learn how to build high voltage magnets see our #HVEMP plans for \$19.95 plus shipping. NOTICE! very important the 600 VDC pulse is only activated at every 2 to 6 seconds. as the steel gets more powerfully magnetized the pulses get longer, like every 15 to 25 seconds. You can use a commutator pulse switcher or any other common type high amp, high voltage switching method. The DC pulsing will cause plasma arcing at the switch and must be controled by common motor methods which we can not reveal.

A friction heater having a heat insulative housing containing inner and outer members with at least one member mounted for rotation relative to the other on a common vertical axis, causes oil to rise up into an annular liquid chamber between the members during rotation to generate friction heat. The inner and outer members are of heavy heat conductive material and are of cup shaped configuration, preferably inverted, to receive the electric motor drive in the resulting, central axially extending space. The outer member has an inner side wall within the cup shaped inner member and the housing has an inner side wall within the members to guide air in a flow path over the motor.

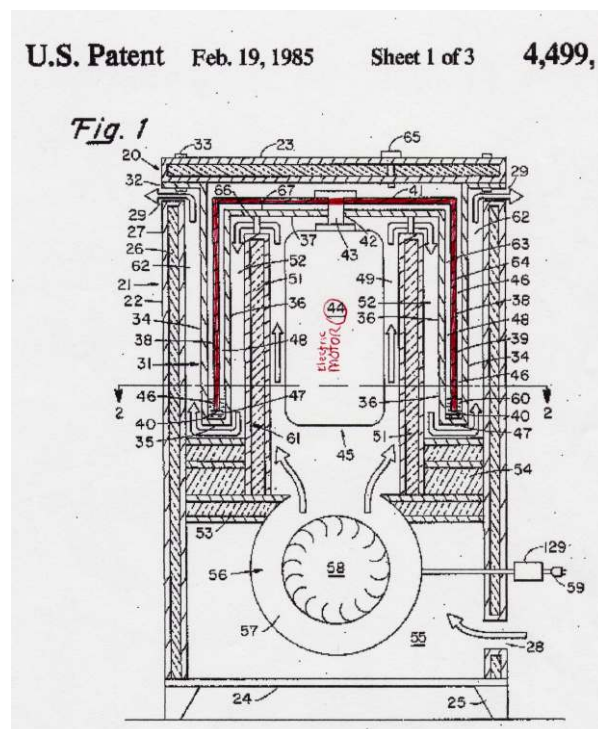

U.S. References:

Claim: I claim:

1. Heat generating apparatus, comprising:

- (a) a housing formed with an air inlet opening and an air outlet opening spaced from one another;
- (b) a relatively fixed cylindrical casing mounted upright in said housing and formed with spaced cylindrical concentric inner and outer walls open at the upper end thereof, and closed at the lower end thereof to define at least one relatively deep annular well at the lower portion thereof for containing a quantity of lubricating liquid therein;
- (c) a cylindrical rotor mounted in said casing for rotation about a vertical axis;
- (d) said rotor being formed with a cylindrical tubular lower skirt extending concentrically into said well and defining a pair of relatively small annular inner and outer clearances with said inner and outer walls of said casing;
- (e) said rotor including a transverse wall;
- (f) power means drivably connected to said transverse wall for rotating said rotor about said vertical axis whereby said liquid will move upwardly in both of said clearances and cause said walls to be heated; and
- (g) air moving means operatively associated with said apparatus for flowing air against the outer surface of said walls between said inlet and outlet openings.

Background/Summary:

Drawing

Descriptions;

Description of

Preferred

Embodiments:

Show background/summary

Show drawing descriptions

DESCRIPTION OF A PREFERRED EMBODIMENT

In FIGS. 1 and 2 a preferred embodiment of the friction heater 20 of the invention is shown, the heater 20 having a housing 21 with an upstanding side wall 22, a top wall 23, a bottom, or base 24 and legs such as at 25.

The upstanding side wall 22, may be of cubical, or cylindrical, configuration and is provided with heat insulation 26, as is the top wall 23, so that the exterior face 27 of the heater is cool to the touch. A cool air inlet 28 and a heated air outlet 29 is provided in housing 21. The insulation 26 not only prevents heat from conduction through the walls 22 and 23 but also serves as sound

insulation to quiet any noise of rotation to the minimum.

An outer member 31 is mounted within housing 21, which preferably is of inverted cup shaped configuration, with an attachment flange 32, fastened by bolts 33 to top wall 23, and a generally cylindrical, upstanding, outer, side wall 34 preferably about fifteen inches in height. The outer member 31, also includes an annular, integral bottom wall 35, an upstanding generally cylindrical, integral, inner wall 36 and a horizontal disc like, annular upper wall 37 to define the above mentioned inverted cup shaped configuration.

The inner member 38 is mounted within the outer member 31 and is also preferably of inverted, cup-shaped configuration with an upstanding, generally cylindrical side wall 39 spaced about one eighth of an inch from the outer side wall 34, and about one eighth of an inch from the inner side wall 36 of the outer member 31. Inner member 38 includes an integral, annular top wall 41 having an opening 42 for receiving the shaft 43 of electric motor 44 of the electric motor drive means 45 of the heater 20. The lower peripheral rim 40 of the inner member 38 is spaced from the annular bottom wall 35 of the outer member about one eighth of an inch.

In a heater of about thirty inches in height, the outer side wall 34 of outer member 31 is preferably about twenty two inches in diameter and about fifteen inches in height with the inner member side wall, and inner side wall of the outer member, spaced apart about one eighth of an inch to form an annular outer liquid chamber 46 of uniform, close clearance, a shallow annular lower liquid chamber 47 and an annular inner liquid chamber 48 also of uniform close clearance.

Because of the preferred, inverted, cup shaped configuration of the inner member 38 and the outer member 31, a central axially extending space 49 is provided for accommodating and receiving the electric motor 44, thereby providing a compact heater. The inner and outer members are preferably of heavy material, the rotating inner member being of one-quarter inch metal and the outer member being also of substantial thickness to prevent bulging of the inner side wall under rotation at the preferred speed of about 1800 RPM while also retaining and conducting heat for a substantial period after rotational friction ceases.

The term "generally cylindrical" is used to describe the upstanding side walls of the inner and outer members because it would be possible to make them slightly truncated conical if desired. It would also be possible to mount the outer member for rotation around a stationary inner member, or to rotate the inner and outer members in opposite angular directions, but cylindrical side walls with the inner member rotating within the outer member on the vertical axis of the shaft of motor 44 is the preferred construction.

The housing 21 includes an upstanding, generally cylindrical inner side wall 51, within and spaced from the inner wall 36 of outer member 31 to form an inner, annular air chamber 52. Side wall 51 is supported by a horizontal annular partition 53 insulated at 54, the partition 53 being supported by housing side wall 22 and forming a lower compartment 55 for powered air circulation means 56 which is preferably a fan, or blower, 57 driven by electric motor 58 from the source of electricity 59.

It will be seen that cool air from the ambient atmosphere is drawn into the cool air inlet 28 by the blower 57 and circulated in the flow path represented by the hollow arrows past the electric motor 44 in the central axially extending space 49 to cool the motor while

picking up heat. The so heated air then reverses direction in the inner annular air chamber 52 to pick up heat from the inner side wall 36, the housing inner side wall 51 acting as the air guide means 61. The heated air then again reverses direction to flow along the outer annular air chamber 62 and thence is discharged from heated air outlets 29.

As in my said patent, a small supply of light oil 60 is normally located in the shallow annular liquid chamber 47, but rises into the outer annular liquid chamber 46 during rotation of the inner member 38 to transfer heat from one member to the other to create frictional heat. It is believed that some of the oil, probably in emulsion form also transfers heat to the inner wall 36 of the outer member during rotation, this wall also becoming heated by conduction of the heavy heat conductive metal.

It should be noted that the supply of oil 60 is captive within the liquid chamber and only partially fills the same so that there is no "flow through" of liquid and the liquid compartments are not full of liquid.

The interior face of the upstanding side wall 39 of the inner member 38 is designated 63, the exterior face thereof is designated 64 and a cap 65 is provided to initially provide a charge of oil 63 in chamber 43, or to replace the same if it becomes slightly depleted after much use.

An apertured ring 66 is affixed to the upper rim of inner side wall 51 of housing 21 to support the partition 67 which in turn supports motor 44 in depending position, while the apertures in the ring 66 permit unimpeded passage of air in the flow path indicated. Motor 44 is preferably a commercially available three horse power electric motor, of the gear motor type rated for about 1725 RPM and about fifteen inches in depth and eight inches in diameter. A drain 68 may also be provided if desired.

Another embodiment of the invention is shown in FIGS. 3 and 4, the housing 71 having a heat insulated side wall 72, floor 73, top wall 74, cool air inlets 75 and heated air outlet 76.

The outer member 77 and the inner member 78 are both of inverted, cup shaped configuration to form the central axially extending space 79 for the electric motor 81. Motor 81 is supported by the inner side wall 82 by the inward projecting lugs 83 and 84, the side wall 82 being supported on vertical, spaced posts 85 from the floor 73. Outer member 77 has an inner upstanding wall 86 which supports upper bushings 87 and tower bushings 88 for rotatably engaging the inner member 78. The inner member 78 is hollow with an inner sealed chamber 89 so that a shallow, annular liquid chamber 91, of considerable width is provided for the oil 92. A drain 93 is provided and the motor 81 is equipped with a magnetic clutch 94 connecting it to the inner member 78 and a second magnetic clutch 95 on the motor shaft 96, connected to a fan 97.

In this embodiment the flow path, indicated by hollow arrows, leads from the cool air inlets 75 up the annular air chamber 98 and out of the heated air outlets 76 picking up heat from the exterior face 99 of the side wall of the outer member. It also leads up the central air space 79, on one side 101 of the motor 81 and down the other side 102 thereof to cool the motor while picking up heat therefrom, the motor being cooled thereby while the air heated by the motor joins the flow path.

Another embodiment of the invention is shown in FIGS. 5 and 6 wherein the inner member 103 and the outer member 104 are both of inverted, cupshaped configuration with the electric motor 105 in the central, axially extending space 106 but both members are

open at their respective tops 107 and 108 so that air flows upwardly and unidirectionally past the motor 105 and past both the inner side 109 wall and the outer side wall 111 of the outer member 104.

Still another embodiment of the invention is illustrated diagrammatically in FIG. 7 wherein the heater housing 112, is insulated and cool to the touch, the inner member 113 and the outer member 114 are of cup shaped configuration with an upper bushing 115 therebetween and a small supply of oil 116 in the shallow liquid chamber 117 ready to rise into the annular liquid chamber 118 upon rotation. An electric motor 119, rotates the outer member 114, on its central shaft 121, by belt and pulley power transmission 122. in one angular direction while an electric motor 123 rotates the inner member 113, on its shaft 124, sleeved on shaft 121, by belt and pulley power transmission 125 and in the opposite angular direction.

The electric motor powered air blower 57 directs ambient cool air up the annular air chamber 126, along the exterior face 127 of the outer member 114 and out of the air outlets 128 back into the ambient atmosphere,

In each of the embodiments of my invention suitable thermostatic control circuits 129 are provided, to cause the rotating member to generate friction heat until a desired temperature is reached, the control circuit then halting rotation while causing the electric motor powered air circulation means to continue to circulate air past the friction heated surfaces until temperature drops to a predetermined figure for a recommencement of the heating cycle. This circuitry and control system is explained in my above mentioned U.S. Patent and therefore is not explained in detail in this application.

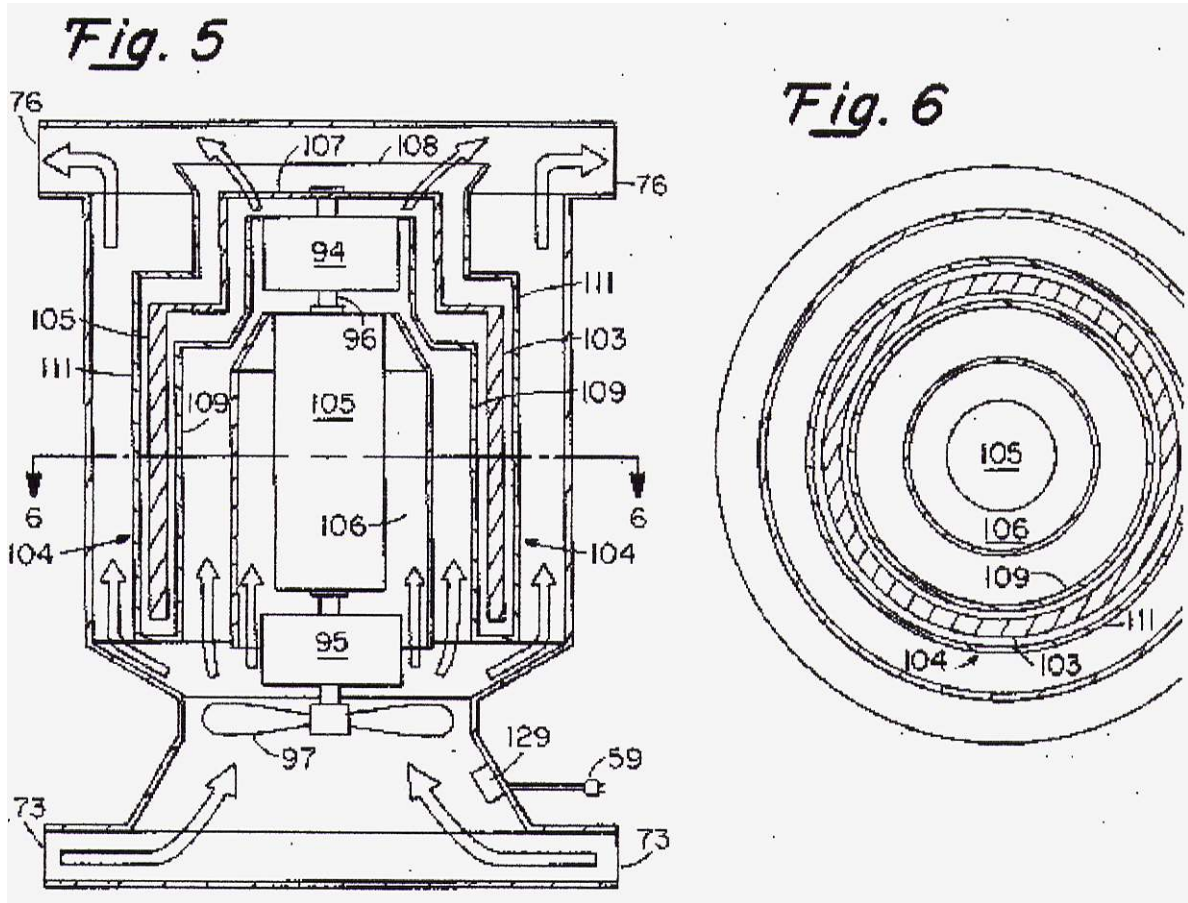

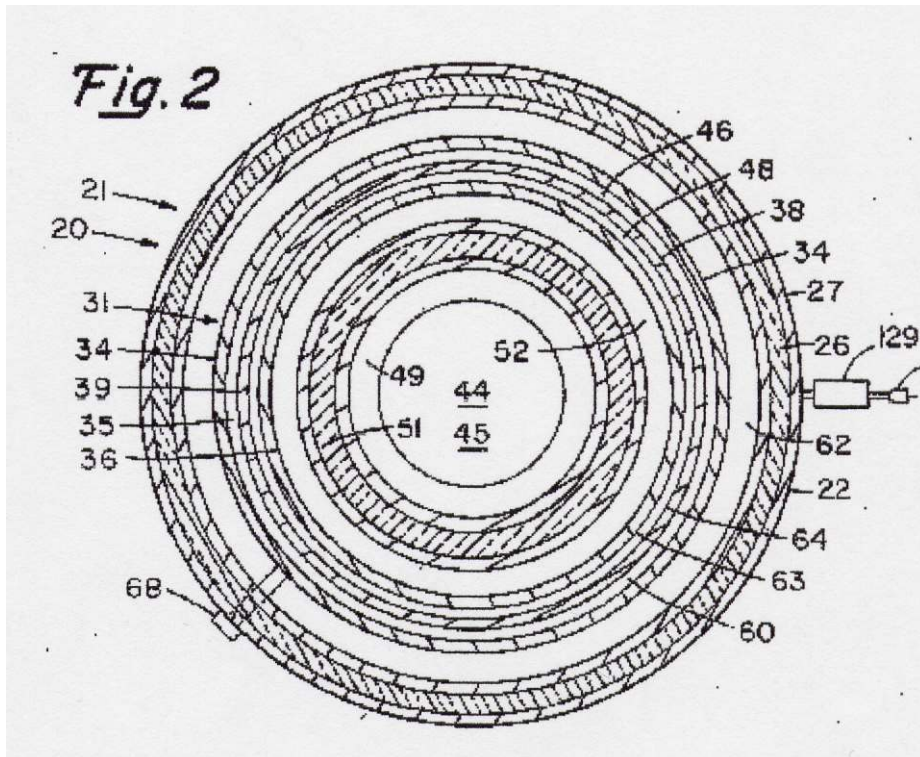
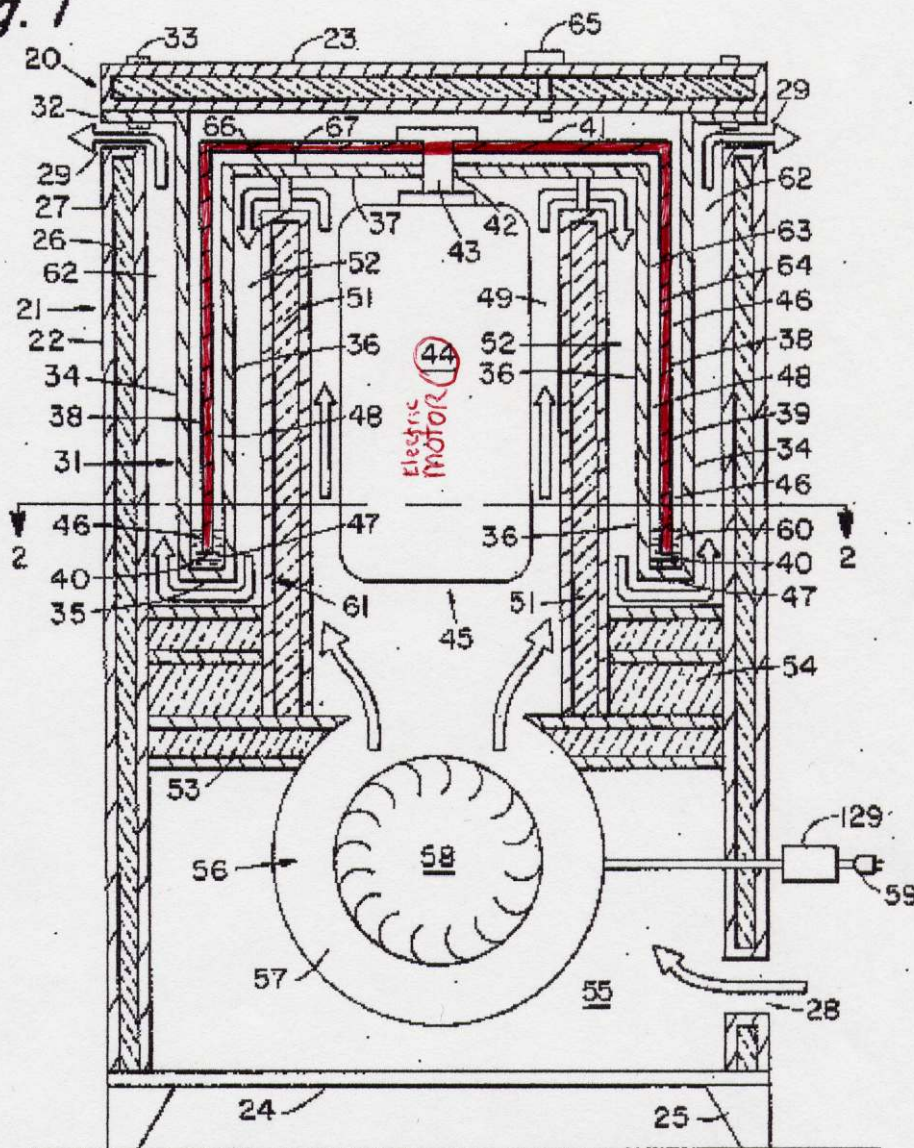
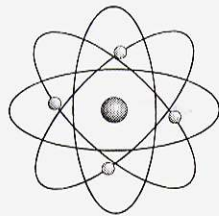

Fig. 1





CREATIVE SCIENCE & RESEARCH

P.O. BOX 557 NEW ALBANY, IN. 47151

Information Big Brother & the Oil Companies do not want you to know!

KNOWLEDGE IS POWER!

4700 uF 35v

CONTACTS
RING
12 VDC coil 75 ma electromagnetic
SIDE VIEW OF 4 PC

Time is running out

2003

FREE ENERGY
www.fuellesspower.com